

IDEAL Fasteners P/L Product Range 2025

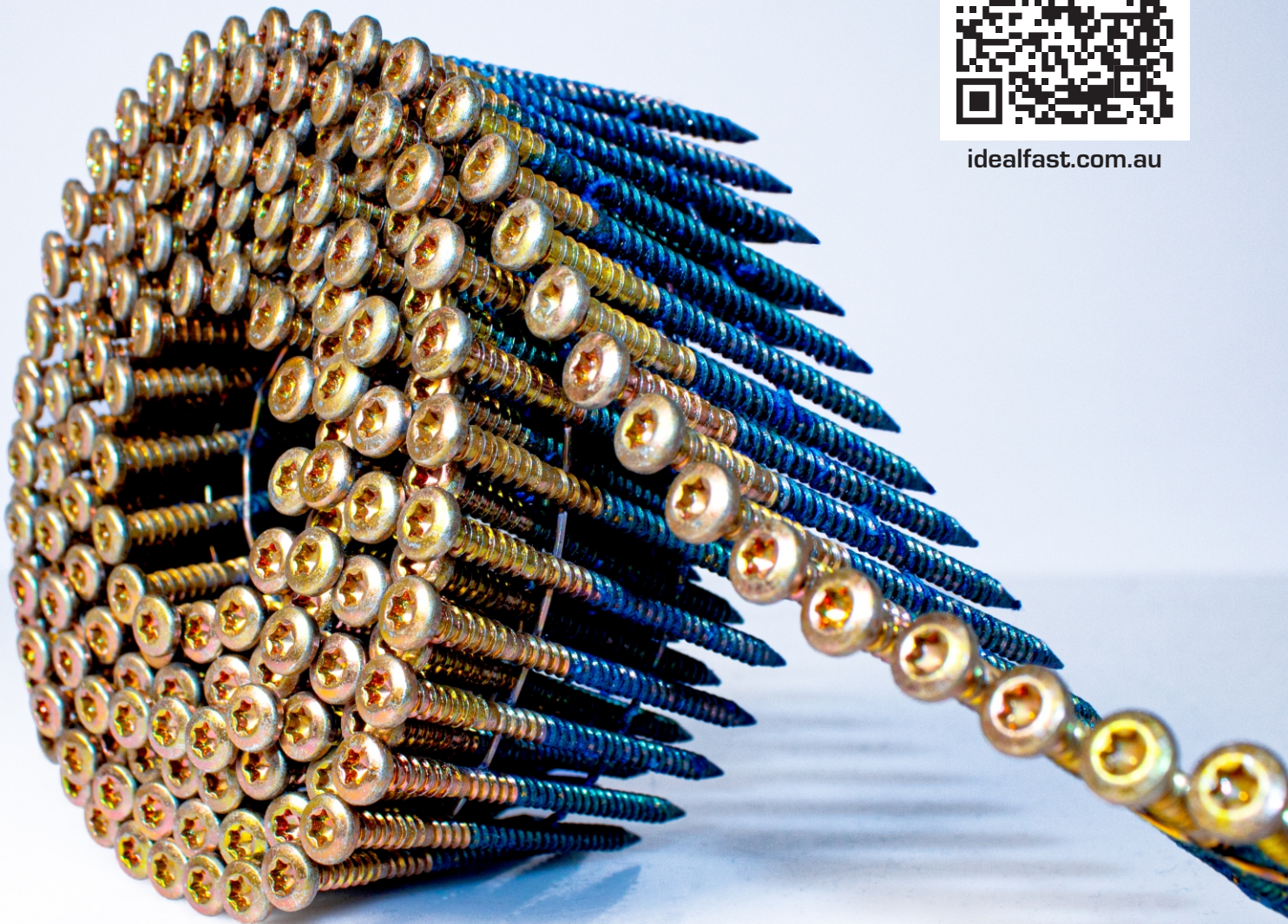

idealfast.com.au



Ranges



1000 Screws

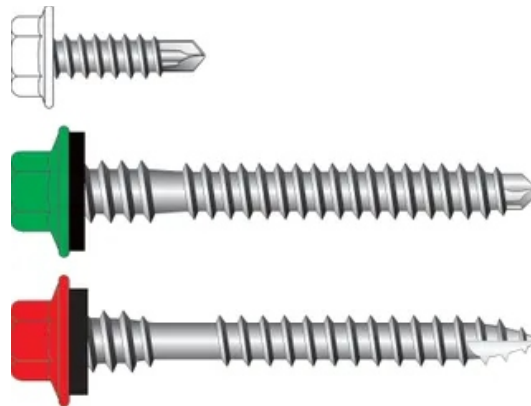

1005 Painted Screws



1100 Collated Screws Systems

Ranges

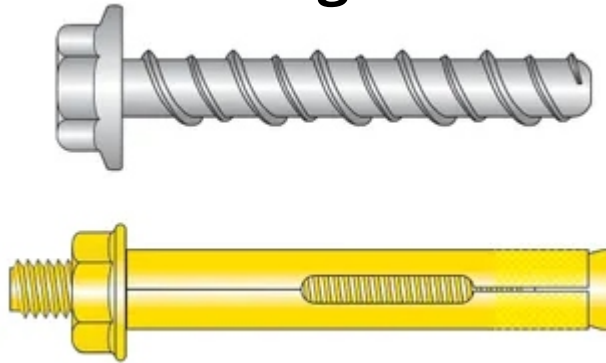

1200 Construction Anchors



1500 Gas Fastening Systems



1600 Powder Actuated Fastening

Ranges



1700 ChemMates™ Adhesive Anchoring Systems

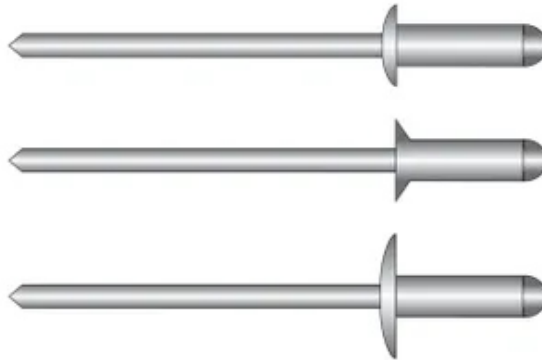

2000 Rivets & Riveting Tools

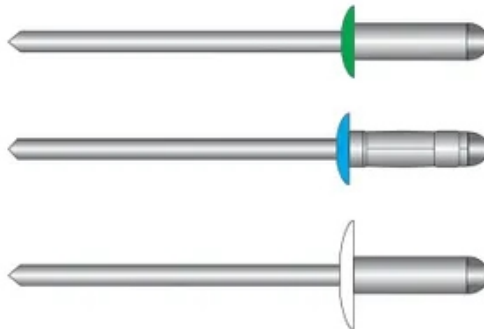

2005 Painted Rivets

Ranges

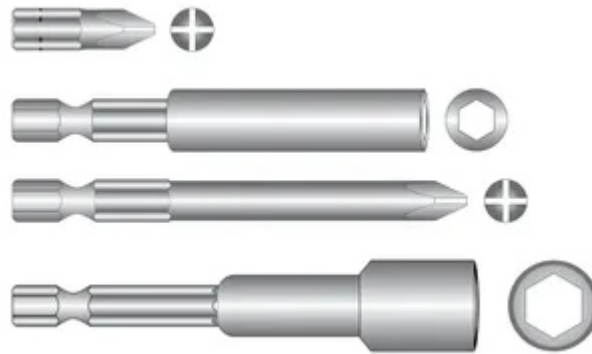

2500 Drivers & Adaptors

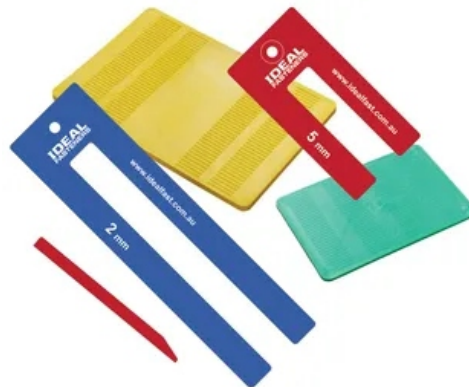

3000 Packers & Shims



4000 Silicones & Adhesive Silicones

Ranges



4100 Sealants & Adhesive Sealants



4200 Adhesives



4300 Foam, Gap & Building Fillers

Ranges

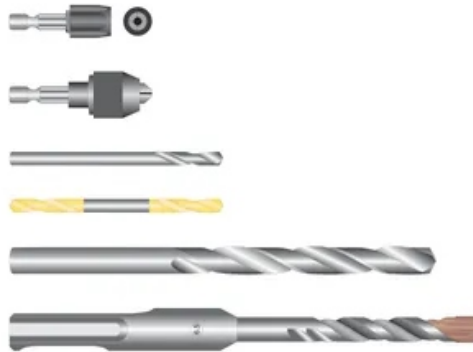

4500 Drilling



4600 Cutting & Grinding



5000 Roof Flashings & Damp Course

Ranges



5200 Purlin, Fascia & Foundation Bolt Assemblies



5500 Steel Framing Industry Products



6000 Washers

Ranges



6500 Foam Panel & Sisalation Fixings



7000 Safety Products

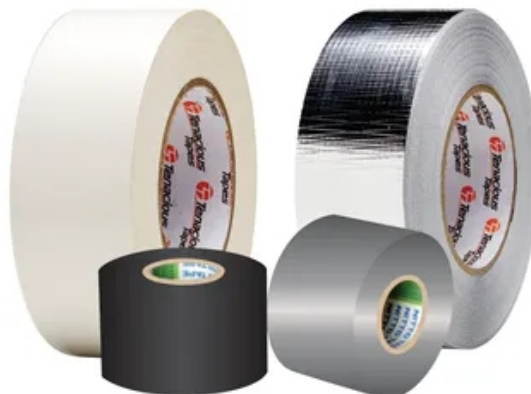

7500 Adhesive Tapes

Ranges



8000 Hardware & Accessory Products

**IDEAL[®]
FASTENERS**
idealfast.com.au

WrapMates[®] Building Wrap system

**Instant fixing to steel
& timber frames**

- Super fast rapid fire installations with bump fire option.
- Automatically fed collated fastener & washer assembly.
- Featuring Mini SCRAIL[®] fasteners for easy removal or adjustment with a standard screwdriver.

WrapMates[™] is a super fast collated fastening system for fixing building wrap to steel frames up to 1.20mm thick.

The fastener with the washer automatically assembled is installed in a single operation. Also suitable for timber frames the WrapMates[™] tool is a light weight, ergonomic, pneumatic tool.

Featuring Mini SCRAIL[®] fasteners in collated coils of 200, they are a combination of a nail and a screw with a PoziDrive recess.

They are shot in, can be reversed out and provide high withdrawal resistance.

Combined with collated Nylon washers in strips of 100 makes for extremely fast and efficient installation.

Continuous shooting of 100 shots before the quick and easy reloading of washers and 200 shots before the equally fast and easy reloading of the Mini SCRAIL[®].

SCRAIL[®] SUBLOC[®] PRO[™] eliminates the squeaking and creaking of subfloors caused by using traditional machine driven nails.

SCRAIL[®] SUBLOC[®] PRO[™] enables quick, easy and uncomplicated floor and subfloor installation. Its special thread ensures that subfloors will continue to withstand loads even years later without creaking or squeaking. Features include:-

- ✓ Aggressive double threads for squeakless subfloors
- ✓ Vastly improved holding power versus plain or ring shank nails
- ✓ Can be used with pneumatic or gas fired tools and can be reversed out using a Torx 15 drive bit

Materials Available: -

- ✓ Standard steel electro - galvanized finish
- ✓ 304(A2) Stainless Steel (lead times apply)



SCRAIL[®] SteelThread[™] for the fastest fixing of subfloors in steel frame construction

SCRAIL[®] SteelThread[™] is driven like a collated nail through panels into steel substrates with FASCO[®] pneumatic or gas powered tools.

Saves time and labour costs:-

Four times faster than collated screws and eight times faster than loose screws.

Up to 2 1/2 times more holding power than screws.

The patented special thread provides excellent holding power in steel from 1.20mm to 1.90mm thickness. Also ideal for use in thinner steel when used in conjunction with an IDEAL Fasteners approved flooring adhesive.

Easily installed and quickly removed.

SCRAIL[®] SteelThread[™] can be unscrewed for removal or adjustment without damaging the material by using Torx T15 driver bit with either hand or power tools.

Collation types include 15° plastic sheet coils or 20° plastic strips.

SCRAIL[®] SteelThread[™] are available with finishes including electro-galvanized or Fascoat[®] for extra corrosion resistance.



IDEAL[®] FASTENERS

idealfast.com.au



Melbourne (Head Office)

**10 - 12 Ausco Place,
Dandenong South Vic, 3175.
Email: sales@idealfast.com.au
Ph: 03 9799 9744
Fx: 03 9799 9755**

Brisbane Branch

**184 Kerry Road,
Archerfield, Qld, 4108.
Email: salesqld@idealfast.com.au
Ph: 07 3275 1900
Fx: 07 3275 1988**

Outside Vic & QLD Area Codes

**Email: sales@idealfast.com.au
Ph: 1300 855 268
Fx: 03 9799 9755**